

Characteristics

Electrical

Power supply

Voltage range: 216.2 - 253V
 Frequency: 50Hz (nom)
 Phases: 1
 Power: Controller 3VA (max)
 Switched output(s)
 75VA
 Fuse: 1.0A slow-blow

Control Relay(s)

Contact type: SPST NO
 Switched Live -
 nominal 230VAC output
 @300mA max.

Thermocouple

Types: K,N,R & S
(Installer selectable)

Connectors

2-part connectors
 Max. wire size 2.5mm²

Error Handling

Thermocouple failure detection
 Thermocouple reversal detection
 Heater failure detection
 Over-temperature detection



This instrument complies with Council Directive 89/336/EEC (electromagnetic compatibility) & Council Directive 73/23/EEC (low voltage safety)

Temperature

Temperature Setting

Range: 0 to 1310°C
 Resolution: 1°C

Control Accuracy

P.I.D. Control
 Reading accuracy: ±0.25% FSD ±1 digit

Time

Time settings

Range: 00:00 to 99hr 59min
 Resolution: 1 min

Programs

20 user programs
 30 segments per program
 Ramp rate 1 to 998°C/hour + full
 Controlled heating & cooling ramps

Environmental

Operating temperature range: 0 to +40°C
 Storage temperature range: -10° to +55°C

Enclosure

Sealing: IP65
 Material: ABS
 Colour: Light Grey RAL 7035
 Size: 160x120x92mm
 Fixings: 148x88mm (4 off)

Stafford Instruments Ltd. www.stafford-inst.co.uk
 Tel: +44(0)1785 255588 email: support@stafford-inst.co.uk
 Fax: +44(0)1785 255589

<http://www.stafford-inst.co.uk/docs/st501/install501.pdf>



ST501

Installation Instructions

ST501 Temperature Controller & (Optional) ST008 Over-temperature Trip



See separate User Handbook for operating details Issue: 2.01
 © Copyright 1999-2005 Stafford Instruments Ltd. Date: 16 Feb 2005

Contents

Safety Warnings 2
 Installer Information 3
 EMC..... 3
 Contact Suppression 3
 Mounting 4
 Wiring 5
 Trip Option 7
 Auxiliary Relay Option 8
 Configuration 9
 Error Messages..... 10
 Characteristics..... 12

Safety Warnings



ISOLATE
 BEFORE
 REMOVING
 COVER

WARNING

ISOLATE KILN & CONTROLLER FROM ELECTRICAL
 SUPPLY BEFORE OPENING THIS INSTRUMENT FOR
 INSTALLATION, CONFIGURATION OR REPAIR PURPOSES

Notes

Error Messages

These errors cause the controller to lock up with the indicated error displayed & heating power turned off. The power to the controller & the kiln should be turned off and the indicated fault rectified.

If an auxiliary control relay configured as an over-temperature O/P is fitted then its contacts will open. An alarm buzzer (if fitted) will sound.

**ERROR 1
NO KILN RESPONSE** This indicates a kiln fault. There is insufficient heating capability. The kiln has been on full power for 1 hour but the kiln temperature has not risen by at least 8°C during this time. Possible problems are: the kiln door or lid may not be closed properly, a heater element may have failed, (on a 3 phase kiln) one of the power phases may be missing, the control relay or contactor has failed open or the thermocouple wiring is short circuit.

**ERROR 2
THERMOCOUPLE O/C** This indicates a broken thermocouple or a bad connection in the thermocouple circuit.

**ERROR 3
T/C REVERSED** A temperature of less than -40°C has been measured. This is interpreted as the thermocouple wiring being reversed.

**ERROR 4
KILN RUN-AWAY** This indicates an electrical fault in the control circuit. The kiln has been on zero power for 15 minutes but the temperature has not fallen by at least 1°C. Control contacts may have failed closed (e.g. welded). **TURN OFF THE KILN.**

**ERROR 5
TEMP TOO HIGH** This indicates that the kiln temperature has exceeded the highest programmed kiln temperature by at least 20°C

Error Messages

Installer Information

Installation Category: II
Pollution Class: 2



230V ~ 50HZ 1.0A

IP65

Fuse: 1.0A Anti-surge
20mm x 5mm ceramic



EMC

The Electromagnetic Compatibility of this instrument has been assessed and tested assuming maximum connecting lead lengths of 3.0 metres. Both the thermocouple lead and the power leads should not exceed this length.

This instrument is designed for use mainly in Domestic & Light Industrial environments where electromagnetic interference may cause a loss of accuracy of the displayed temperature reading of up to 3°C. Specified accuracy will be restored when the interference is removed.

EMC

Contact Suppression

The coil of each contactor **must be suppressed** with an RC filter network. The RC network must be connected directly across the coil terminals on the contactor.

Suitable proprietary RC filter networks fitted with insulated wire leads are:-

- | | | |
|----|-------------------------------|------------------|
| 1. | RS Components | Part No. 210-364 |
| 2. | RS Components (tab fixing) | Part No. 210-370 |
| 3. | Farnell Electronic Components | Part No. 218-893 |

Suppression

Mounting

Mounting Location

Mount the instrument on a suitable vertical surface which will not get hot. Choose a position where the instrument is not exposed to direct heat from the kiln - especially when the kiln door or lid is open.

The cable entry in the instrument base should normally be positioned downwards to guard against moisture ingress.

Mounting Centres

The mounting centres are marked on the back of the instrument enclosure and are 88mm x 148mm.

To expose the mounting holes in the instrument base remove the instrument's front panel which is secured with cross-head screws.

Quick Release Mounting Bracket

This 2-part steel wall-mounting bracket is available as an accessory and is useful if an umbilical cord with a connector is fitted to the instrument—allowing quick removal of the instrument for repair.

Configuration

The ST501 can be configured for a particular kiln with the INSTALL menu.

To enable the INSTALL menu press & hold down the **SET** key while powering up the controller - releasing the **SET** key when READY is displayed. If **SET** is now pressed again then the INSTALL menu can be found with the **↑** key. The INSTALL menu is entered with the **→** key and is described on the next page. Installable parameters are changed with the **↑** & **→** keys causing a STORING... message to be displayed.

After configuration exit the INSTALL menu either by selecting EXIT INSTALL or by pressing the **SET** key a number of times. Turn the mains power to the controller off then on to remove the INSTALL menu.

THERMOCOUPLE r NEXT INSTALL u	This allows the thermocouple type to be selected as K,N,R or S type. The factory setting is 'R' type. To exit the thermocouple selection menu press the SET key.
----------------------------------	---

ERROR HANDLING r NEXT INSTALL u	This allows error codes 1,4 & 5 to be disabled or enabled. The factory settings are: all enabled. These error messages are provided to detect kiln faults and so offer some protection for the kiln. It will only be rarely necessary to selectively disable error messages in special situations if nuisance error messages occur.
------------------------------------	---

CLEAR PROGRAMS r NEXT INSTALL u	This clears the factory-set program data from programs 01 to 10.
------------------------------------	--

LOAD PROGRAMS r NEXT INSTALL u	This re-loads the factory-set program data into programs 01 to 10.
-----------------------------------	--

KILN POWER r NEXT INSTALL u	This sets the kiln power rating in kW. This is used to calculate the ENERGY USED display.
--------------------------------	---

AUX RELAY r NEXT INSTALL u	This menu item only appears if an auxiliary relay is fitted. This relay can be configured as a damper, event or over-temperature / alarm output.
-------------------------------	--

Auxiliary Relay Option

Description

To determine if this option has been fitted examine the external yellow serial number label—the option 'A' should be marked. An extra relay is fitted to RL3 position. This auxiliary relay can be configured to operate in one of the three modes described below. See the Configuration section for how to set up the operating mode via the INSTALL menu.

Damper Output

In this mode the auxiliary relay can automatically control an electrically operated damper. It is assumed that the damper closes when the relay contacts close. The user can set the damper closing & opening temperatures via a SET DAMPER menu. The damper closes the first time that the kiln temperature exceeds the user-set damper closing temperature. The damper opens during natural cooling at the end of a firing when the kiln temperature has fallen below the user-set damper opening temperature.

Event Output

In this mode the auxiliary relay is under program control. Each segment of the program has an additional EVENT ON (relay contacts closed) or EVENT OFF (relay contacts open) command available for both the ramp & the soak sections of each segment.

Over-temperature / Alarm Output

In this mode the auxiliary relay contact closes at the start of a firing & opens at the end of the firing. The contacts also open if an error condition is detected. The auxiliary relay can be used to control a secondary contactor wired in series with the heating contactor. This security feature will cut off kiln heating under error conditions.

Wiring

Connector

If the instrument has been pre-wired with a cable & plug ensure that the plug is compatible with the connector fitted to the kiln. The standard connector is Harting type HAN 7D.

HAN 7D Pinout

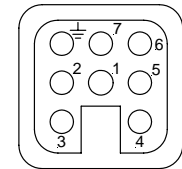

View on pins

Kiln Connections

Compatible kiln connector wiring is shown below:-

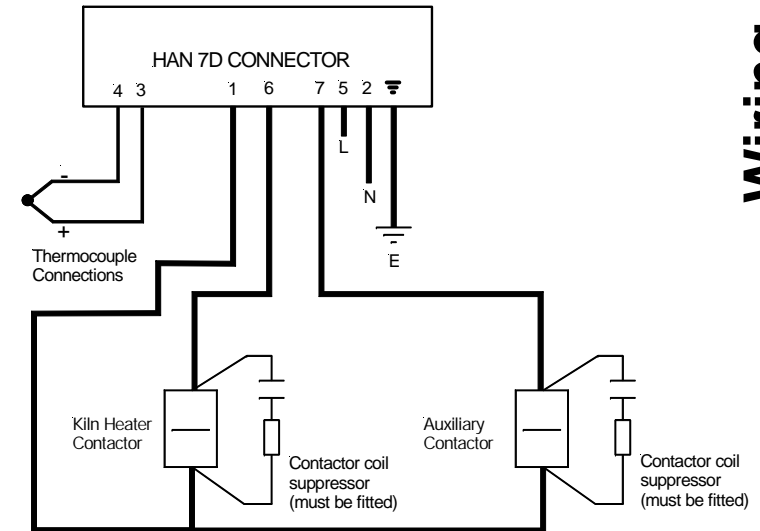

Wiring

Connector Pin List

1	Neutral to contactors	5	Mains Live supply
2	Mains Neutral supply	6	Kiln Power contactor Live
3	Thermocouple +	7	Auxiliary contactor Live
4	Thermocouple -	Earth	Earth

Trip Option

Wiring In

If a pre-wired cable & plug is not fitted then the instrument can be wired to the kiln as shown below. The instrument is fitted with 2-part connectors to facilitate wiring. The maximum wire size is 2.5mm².

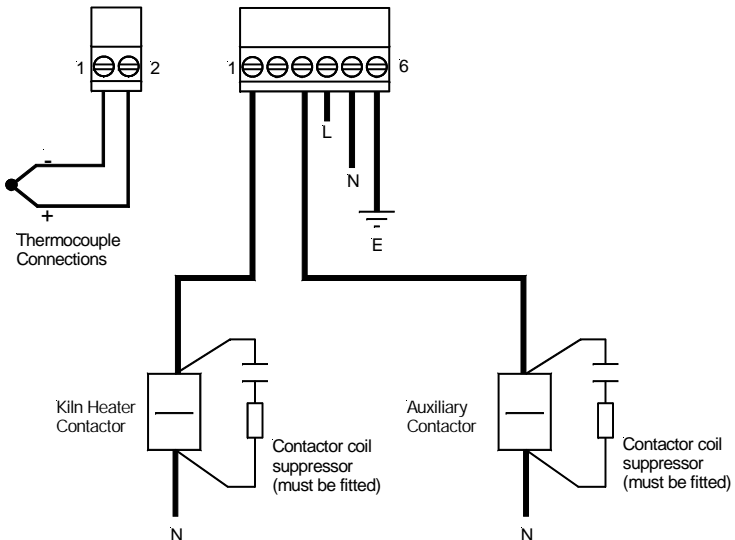
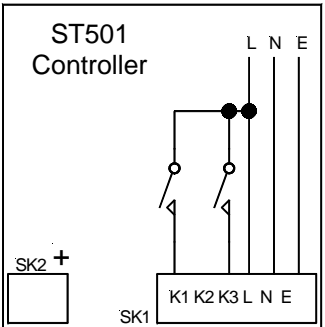

Wiring

Description

The ST008 over-temperature trip module is designed solely for internal fitment to the ST501 temperature controller. It is an optional safety device designed to protect kilns & furnaces from over-firing. It behaves like a re-settable heat fuse.

Installation

Remove the red jumper plug J3 & discard. Check that the thermocouple type settings on the trip module and the controller match by ensuring that the yellow jumper on the trip (J1) is correctly set. Plug the trip module into the controller printed circuit board so that it mates with both J3 & PL1 on the controller's circuit board.

Trip Temperature Selection

The trip temperature is set by switch SW1 mounted at the top of the trip module. This switch has 16 positions and can be adjusted with a small flat bladed screwdriver:-

Switch Position	Thermocouple Type		Switch Position	Thermocouple Type	
	R & S	K & N		R & S	K & N
0	1000°C	650°C	8	1320°C	850°C
1	1050°C	675°C	9	1330°C	875°C
2	1100°C	700°C	A	1340°C	900°C
3	1150°C	725°C	B	1350°C	925°C
4	1200°C	750°C	C	1360°C	950°C
5	1250°C	775°C	D	1370°C	975°C
6	1300°C	800°C	E	1380°C	1000°C
7	1310°C	825°C	F	1400°C	1025°C

Operation

In the event of an over-temperature condition the trip will operate. This is indicated by a normally hidden 'FAULT' legend illuminating in red on the controller's front panel. The trip module removes power from the switched outputs of the controller thus turning off the kiln contactor and the auxiliary contactor (if fitted). The only way of re-setting the trip is to turn off the mains supply to the controller, wait a few seconds then turn the power on again. If the fault is still present the trip will operate again after about 5 seconds.

Trip Option